

8) PERFORM OTHER CRIMPINGS IN THE SAME WAY.

5. Attention

1) BEFORE USE THE TOOL, inspect the general condition of the tool, check for loose screw, misalignment or binding of moving parts, cracked or broken parts, and any other condition that may affect its safe operation.

1) Do not drop the tool on to the ground, it will caused damaged.

2) Do not expose the tool to the raining and damp air.

3) AFTER USE, clean external surfaces of the tool with clean, moist cloth.

INSTRUCTION

HT-150



www.fivestar-tools.com

6. Troubleshooting

1) the upper die can not fixed.

Reason: the screw in the upper shoe loose.

SOLVE: Use the accessories "screwdriver" to screw the nut tightly. Pleas as following

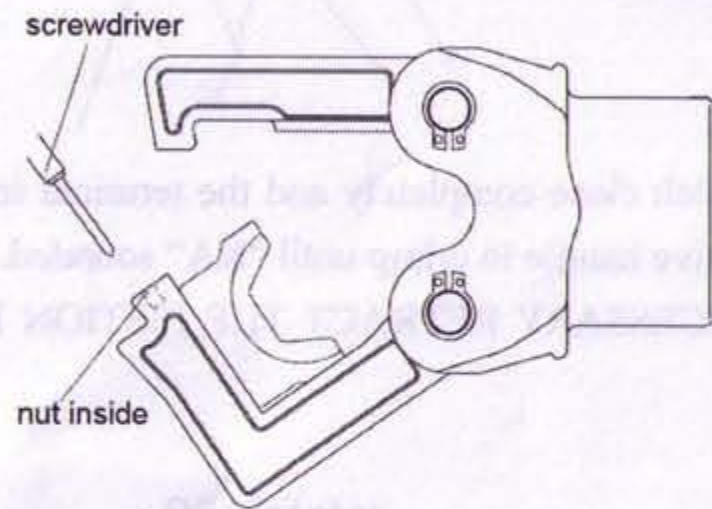

7. Technical Data

Item No.	HT-150 with safety system inside
Crimping range	4-150 mm ²
Crimping force	35KN
Material of tool	Aluminum alloy
Size	
Crimping type	Hexagon crimping
Weight	1.36kg
Package	Plastic box
Accessories:	
Crimping die	4.6.8.10.16.25.35.50.70.95.120.150mm ²

Screwdriver	1 pc
-------------	------

1. Instruction

Before starting use the tool read this manual. Failure to do so can result in serious injury. The mounting and assembly of material must only be performed by trained personnel. The life span of the tool is 10 years. Please comply the rule of manual strictly when use the tool.

2. Warranty

Warranty is 12 months from the time of delivery and under correct operation.

3. Description of units

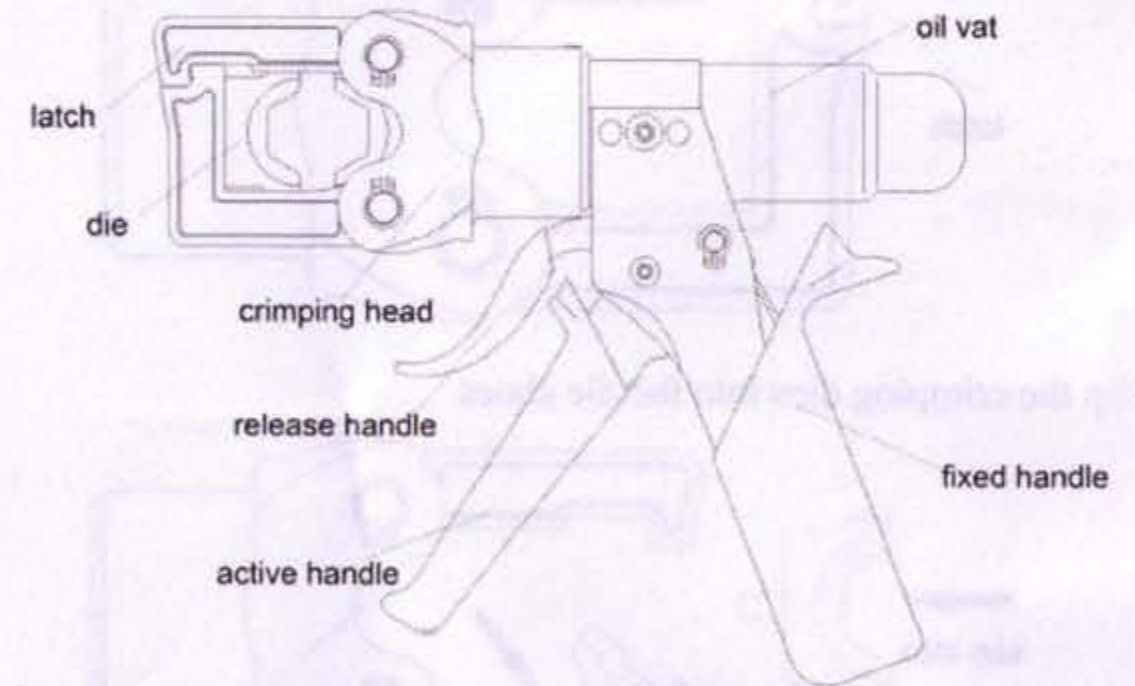

No.	Description	Function
1	Oil vat	For containing the oil
2	Fixed handle	To grip the handle
3	Active handle	For operation to offer the propulsion

4	Release handle	To release the pressure
5	Crimping head	For located the crimping die
6	Die	For crimping the lugs
7	Latch	Open it to set the crimping die

4. Operating instruction

- 1) First select the right die for the intended application.
- 2) Push the latch as “flip top” showing,

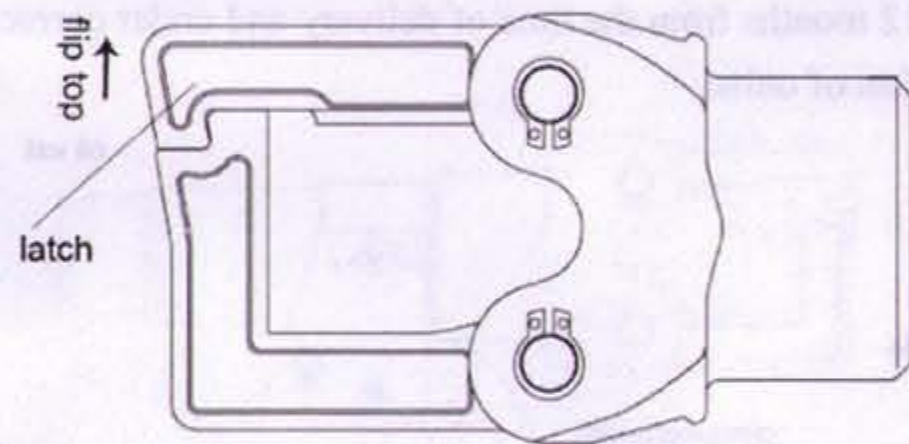

- 3) Slip the crimping dies into the die shoes

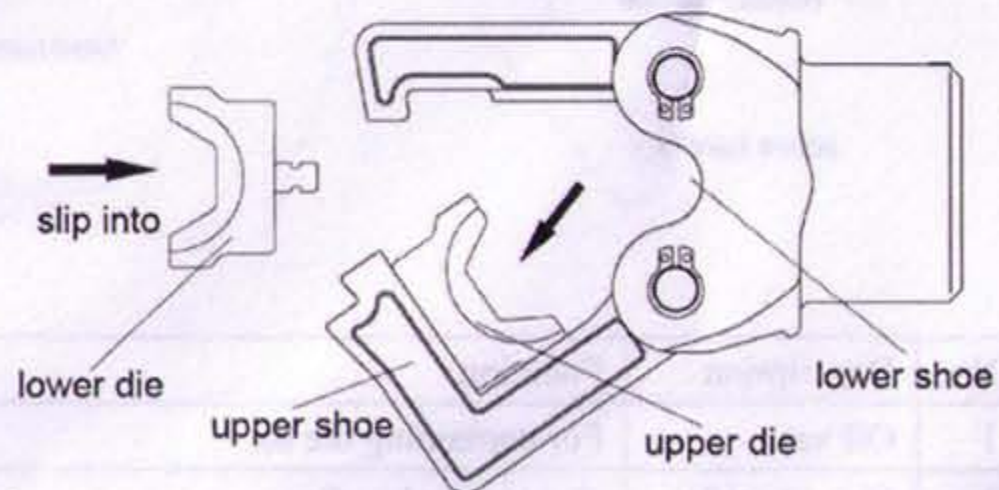

- 4) Put the connector between the two crimping dies then clic the latch completely close. Adjust a reasonable angle of the crimping head in need.

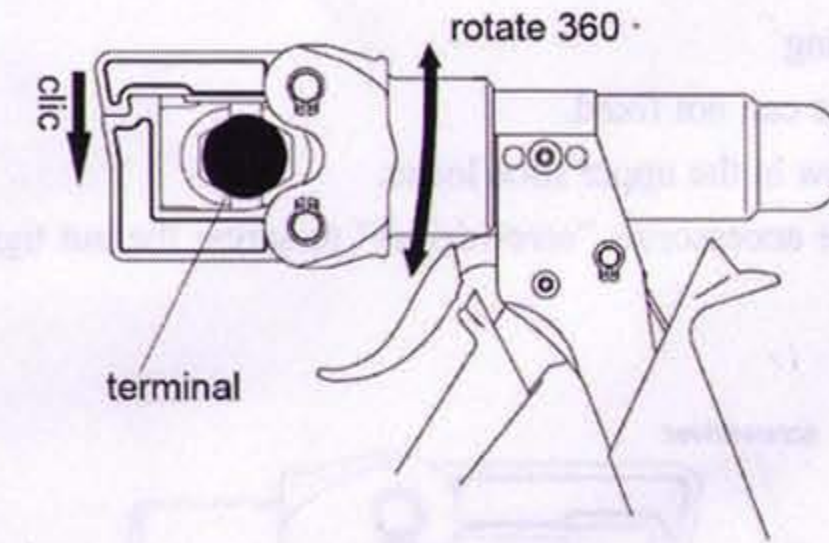

- 5) Make sure the latch close completely and the terminal in right position then press the active handle to crimp until “KA” sounded.
ATTENTION: IF NECESSARY RETRACT THE PISTON BY RELEASE HANDLE

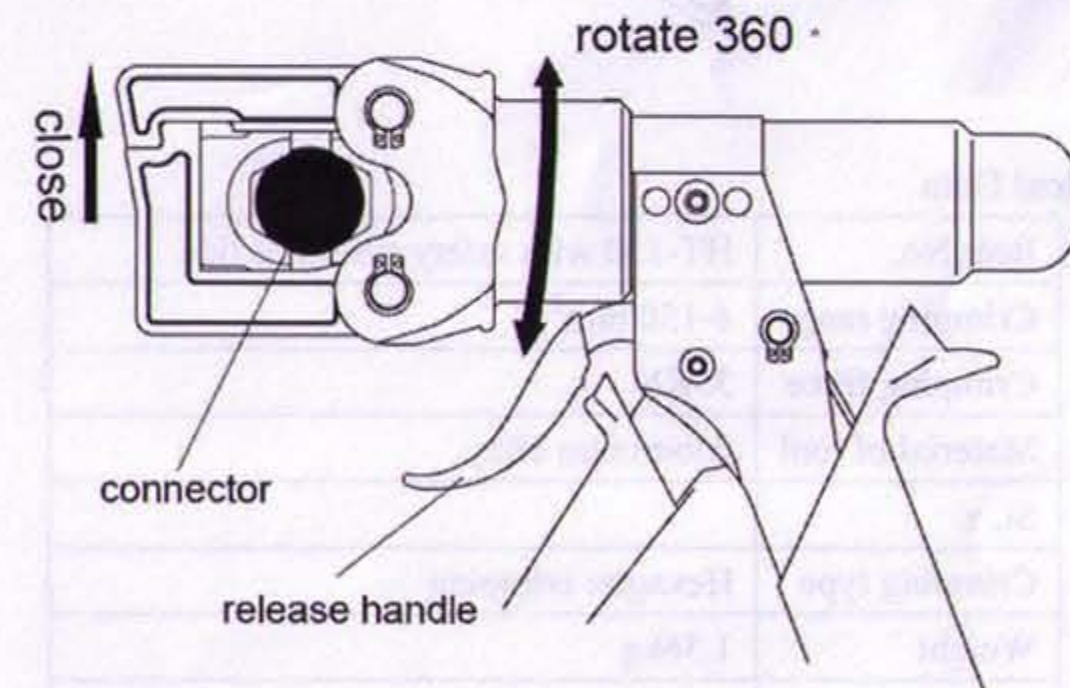

- 6) After the above 5 steps, the crimping finished.
- 7) RELEASE THE PRESSURE: activate the release handle lightly, open the latch to pull out the connector