

**Instruction of Pipe Bender  
(Integral-unit SWG series)  
Fivestar Tools Co., Ltd**



8. Put the lock cap (NO.18) into the inner hole of vat plug. fasten the lock-cap and connect with the vat pipe. Then put the inner lock-cap into the big lock-cap fasten.

**Note: above 7 steps the contour of bender will be finished.**

9. Mount the front wheel rack (NO.16) and front wheel (NO.15) to the down wing (NO.17), then fixed the vat plug (NO.8) with four hex-caps.

10. Mount the back wheel rack (NO.27) and front wheel (NO.26) to the below of the pump body.

11. Set up the up wing (NO.10) to the vat plug (NO.8) then insert the wing plug (NO.9) and insert the plug of sustain rack (NO.14) to the hole of mould wheel (NO.13), after blocked by block-spring, then insert into the holes of both up wing (NO.10) and down wing (NO.17).

12. When in operating, open the oil cap of the oil jaws, check the oil

If empty or not full, please fill full the oil (L-HV15) and assemble the

13. Mould (NO.11) to the head of piston, when working please daub the lube to the concave of mould (NO.11) and mould wheel (NO.13). Then wear the handle sleeve (NO.12) to the handle (NO.6), Last, insert one end of the handle (NO.6) into the hole of handle rack (NO.2), starting working then.

**Technique Parameter**

**Hydraulic oil: L-HV15 hydraulic oil**

Item No	Output (T)	Travel (mm)	Outside Dia.	Mould Disposition	Thickness of Pipe(mm)	Weight (kg)
SWG-1	10	170	Φ13mm-34mm	1/4" 5/16" 3/8" 1/2" 3/4" 1"	1-3.5	20
SWG-2	16	240	Φ22mm-60mm	1/2" 3/4" 1" 1 1/4" 1 1/2" 2"	2.75-4.5	44.5
SWG-3	18	320	Φ22mm-89mm	1/2" 3/4" 1" 1 1/4" 1 1/2" 2" 2 1/2" 3"	2.75-6	91
SWG-4	20	380	Φ22-108mm	1/2" 3/4" 1" 1 1/4" 1 1/2" 2" 2 1/2" 3" 4"	2.75-6	126.5

**Introduction**

The pipe bender is suit for bending welding steel tube which has low pressure to deliver liquid in cold situation. It is also suit for bending common water pipe; carbon steel pipe and thick-wall conduit tube. It is not suit for bending the steel pipe with different diameter and colored metal pipe. The machine can be use in building, Petrol, mines and shipbuilding industry.

**Working Method**

1. Turn the switch tightly with clockwise direction.

2. Loosen the bolt.

3. Add lubrication on mould and the pipe.

4. Choosing corresponding mould base on size of pipe, set mould on the top of actuating rod. Then insert the rocker on nether molding board. Put the pipe, turn two rockers and make the groove point to the mould.

5. Turn back the upper mounding board; shake the handle of pump to make the mould press the pipe, bending the pipe until the angle is shaped.

6. After bending. Loosen the switch anti-clockwise. The actuating rod would be back automatically. Open the upper molding board, get out the pipe.

**Attention Item**

1. Diameter and the thickness of wall

Φ 127	Φ 159	Φ 19	Φ 213	Φ 268	Φ 305	Φ 423	Φ 48	Φ 60	Φ 755	Φ 885	Φ 108	Φ 133
2	2	25	275	275	325	325	35	35	375	4	45	5

If the thickness of steel pipe is less than the diameter number, it is called thin-wall conduit tube. After bending the thin-wall conduit tube it would appear ruffle.

2. Before using, loosen the bolt to aerate.

3. The switch should turn tightly before bending, otherwise the pressure could not exist in such situation.

The size of the tube must be suit for the grooves otherwise the bend pipe will

4. appear curves or splits.

5. The pipe and two rockers must be lubricity, the welding gap of pipe can not put toward

outside and inside of the bending part.

6. When you are working, the air may get inside of the machine. Shake the handle and make the pump working. Get out the actuating rod, open the head of oil-vat and make the bender in the situation angle of declining 45°. Then loosen the switch anti-clockwise, let the air get out, if air is still inside, do it again and again.
7. Insert two rockers should be symmetry and make sure that they are in the right stage.
8. Costumers use our products should apply the main technique parameter. Warning that working can not be overloaded to avoid damage.
9. The machine should be clean. The oil must be filtered clean by 200-mesh net to avoid impurity in it.
10. It is not suitable for being used in acid, alkali and corrosive gas.
11. The pressure has been adjusted in factory, costumers do not adjust it at will.
12. If the machine finishes working, you should turn the valve switch tightly.

#### Instruction of assemble of bender

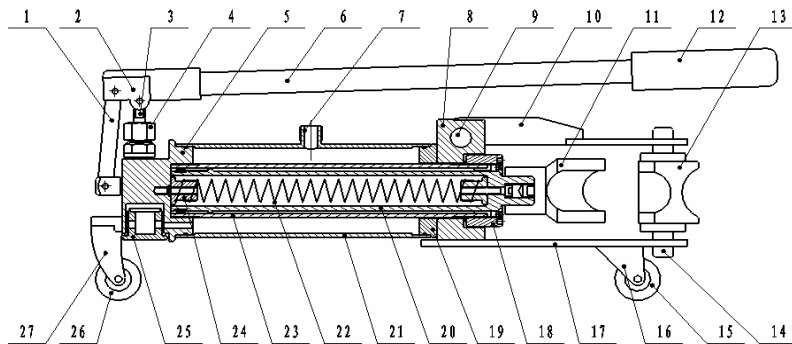

#### Description of the components

1: pull sheet	2.handle rack	3.pump cartridge
4:pump cover	5:pump body	6: handle
7. oil jaws	8. vat plug	9: wing plug
10. upper wing	11.bender mould	12. handle sleeve
13.mould wheel	14.plug of sustain wheel	15. front wheel
16. front wheel rack	17.down wing	18. lock cap
19. ring of press sheet	20. piston	21.outer vat pipe
22.spring	23. vat pipe	24. spring plug
25.filtration cap	26. back wheel	27. back wheel rack

1. Firstly (NO. 5) set up the steel ball, spring, valve to the head of pump. Then (NO. 3) set up the pump cartridge and pump sleeve (NO.4). Last fitting the pull sheet (NO.1) and handle rack (NO.2).
2. Assemble the pump body to the pliers. Put the O-Ring into pump1.
3. Body, then screw the spring which with screw cap into the pump body (NO. 22).
4. After mount the “v” type O-Ring to the O-Ring groove of big end of (NO.20) piston, wrapping the spring outside. Meanwhile fasten the pull rod into the small end of piston. Screw the bolt plug to the small piston.
5. Wrap the piston by pump pipe (NO.23) and screw one end fasten, put the other end with leading- ring out of the piston but between pump pipe and piston.
6. Mount the O-Ring to the outer of pump jaws, embed the out vat pipe (NO.21) TO the pump body, then set up the O-Ring to the ring of press sheet(NO.19)and cover the other end of out vat pipe, forcibly so that in seal station.
7. Put the O-Ring to the tangency between ring of press sheet and vat pipe, then put the vat plug (NO.8) onto the ring of press sheet.